

DC EXHIBIT G

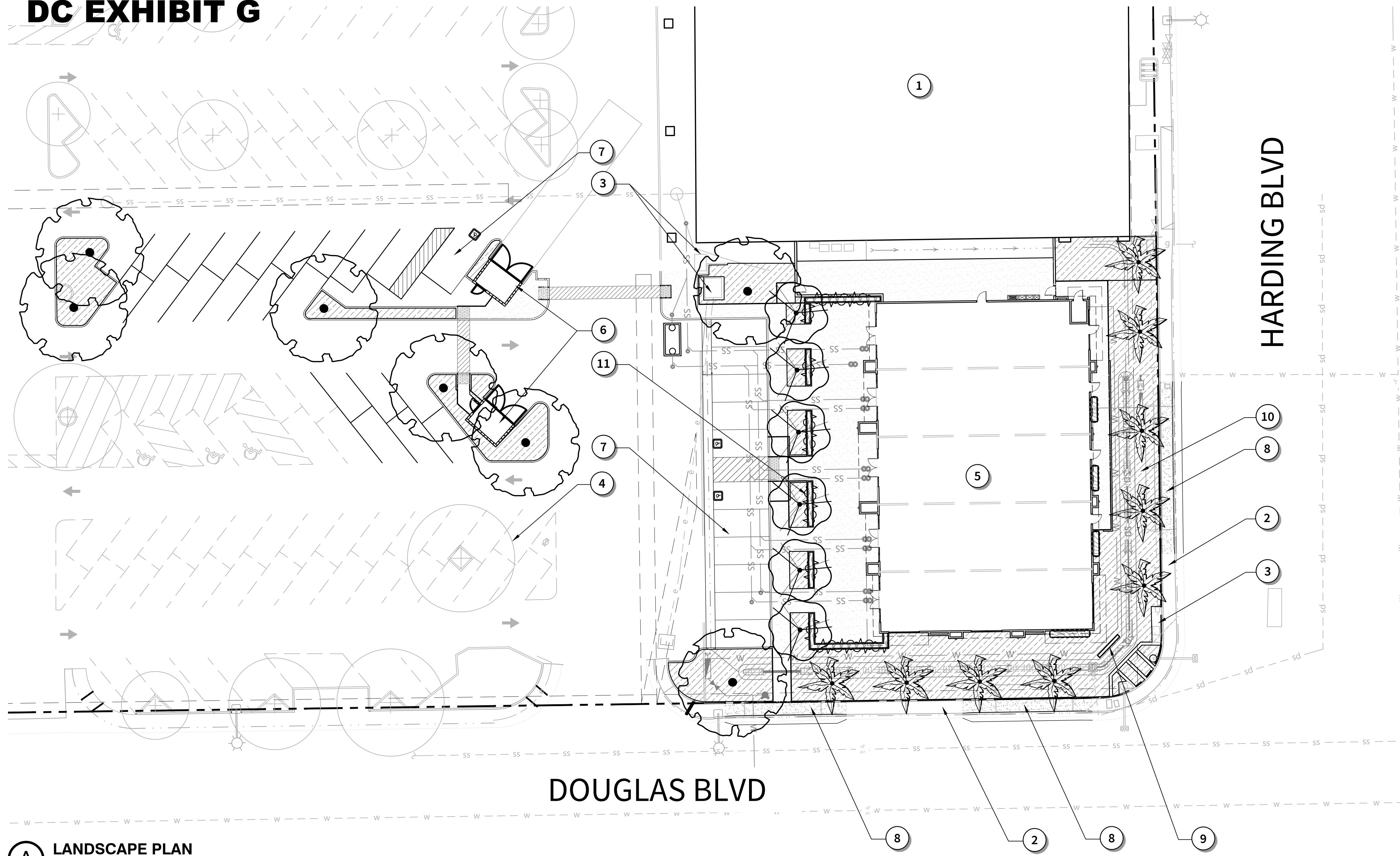

A LANDSCAPE PLAN
1"=20'-0"

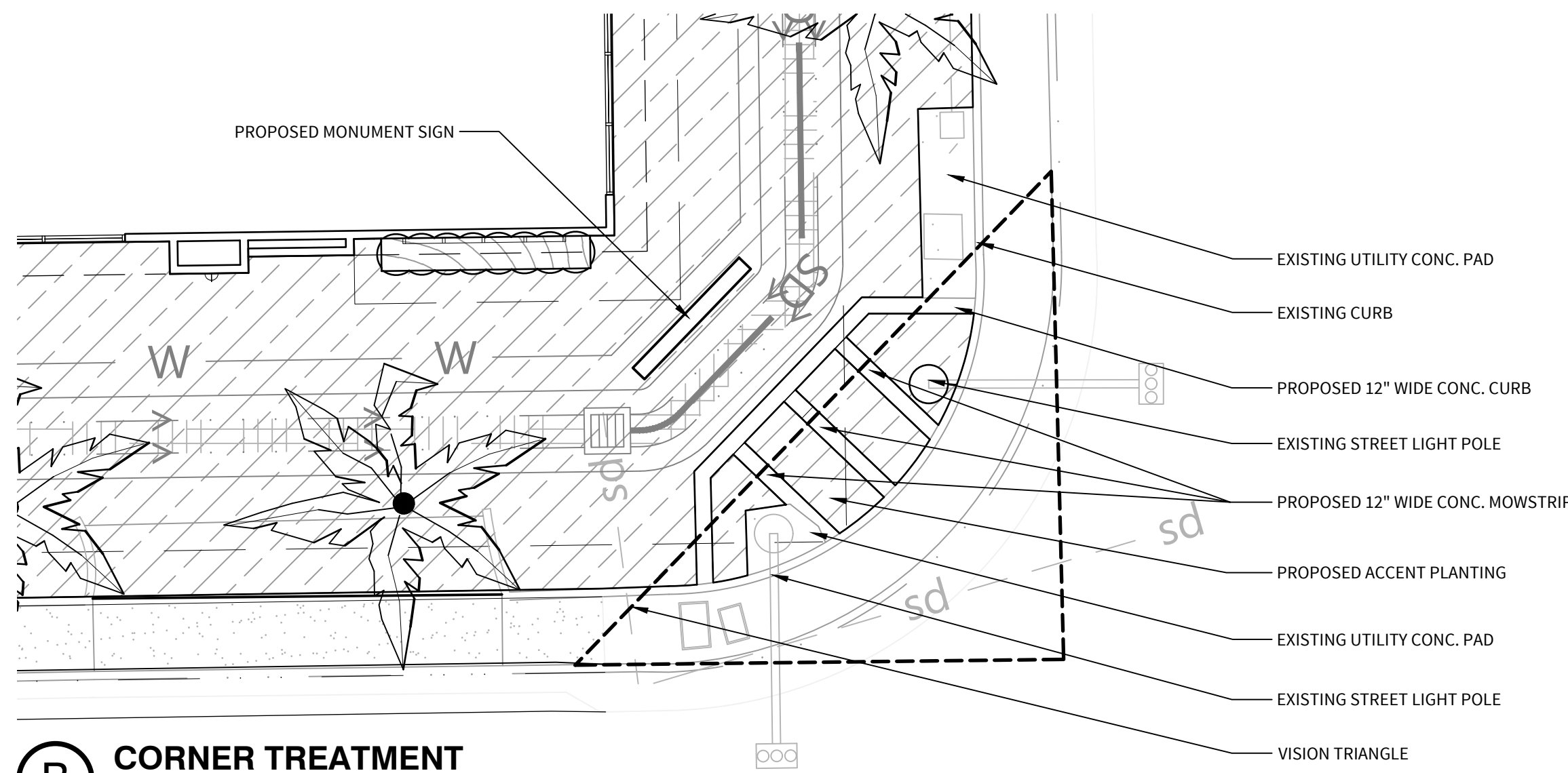

B CORNER TREATMENT
1"=10'-0"

PLANT SCHEDULE

SYMBOL	BOTANICAL NAME	COMMON NAME	SIZE	WATER USE	QTY
TREES					
	PHOENIX DACTYLIFERA	DATE PALM	12 BTF	LOW	9
	PISTACIA CHINENSIS 'KEITH DAVEY'	KEITH DAVEY CHINESE PISTACHE	24" BOX	LOW	7
	ZELKOVA SERRATA 'JFS-KW1'	CITY SPRITE® JAPANESE ZELKOVA	15 GAL.	MOD	6
SHRUB AREAS					
ACCENT SHRUBS/GRASSES					
	DIETES BICOLOR	FORTNIGHT LILY	1 GAL.	LOW	
	MUHLENBERGIA RIGENS	DEER GRASS	1 GAL.	LOW	
	SALVIA GREGGII 'HOT LIPS'	AUTUMN SAGE	5 GAL.	LOW	
	LAVANDULA ANGUSTIFOLIA 'HIDCOTE'	HIDCOTE ENGLISH LAVENDER	1 GAL.	LOW	
FOUNDATION/SCREENING SHRUBS					
	GREVILLEA X 'NOELLII'	GREVILLEA	5 GAL.	LOW	
	LIGUSTRUM SINENSE 'SUNSHINE'	SUNSHINE LIGUSTRUM	5 GAL.	LOW	
	RHAMNUS CALIFORNICA 'EVE CASE'	CALIFORNIA COFFEEBERRY	5 GAL.	LOW	
GROUNDCOVERS					
	CISTUS X 'SUNSET'	MAGENTA ROCKROSE	1 GAL.	LOW	
	COTONEASTER DAMMERI 'LOWFAST'	LOWFAST BEARBERRY COTONEASTER	1 GAL.	LOW	
VERTICAL VINES					
	TRACHELOSPERMUM JASMINOIDES	CHINESE STAR JASMINE	1 GAL.	MOD	
PLANTERS					
	CARISSA MACROCARPA 'BOXWOOD BEAUTY'	BOXWOOD BEAUTY NATAL PLUM	1 GAL.	LOW	
	DIANELLA REVOLUTA 'DR5000'	LITTLE REV™ FLAX LILY	1 GAL.	LOW	
	DIANELLA TASMANICA 'VARIEGATA'	VARIEGATED FLAX LILY	1 GAL.	MOD	
	LOMANDRA LONGIFOLIA 'ROMA 13'	PLATINUM BEAUTY® VARIEGATED MAT RUSH	1 GAL.	LOW	

REFERENCE NOTES SCHEDULE

SYMBOL	DESCRIPTION
1	EXISTING RETAIL BUILDING.
2	EXISTING CONCRETE SIDEWALK TO REMAIN.
3	EXISTING UTILITIES TO REMAIN.
4	EXISTING PARKING LOT TREE TO REMAIN.
5	PROPOSED RETAIL BUILDING, SEE ARCHITECT PLANS.
6	PROPOSED TRASH ENCLOSURE, SEE ARCHITECT PLANS.
7	PROPOSED PARKING STALLS, SEE CIVIL PLANS.
8	PROPOSED CONCRETE SIDEWALK, SEE CIVIL PLANS.
9	PROPOSED MONUMENT SIGN, BY OTHERS.
10	PROPOSED LANDSCAPE AREAS.
11	PROPOSED 30" TALL PLANTER POT.

SHADE CALCULATIONS

TOTAL PAVED AREA = 3,780 S.F.			
TOTAL SHADE REQUIRED (50%) = 1,890 S.F.			
TOTAL SHADE PROVIDED (93%) = 3,521 S.F.			
DIA.	QTY.	S.F.	TOTAL S.F.
35' TREES (PIST, CHIN)			
100%	0	962	0
75%	1	722	722
50%	4	481	1,924
25%	2	240	480
20' TREES (ZELK, SERR)			
100%	0	314	0
75%	0	236	0
50%	0	157	0
25%	5	79	395
TOTAL SHADE PROVIDED:			3,521 S.F.

PRELIMINARY LANDSCAPE DESIGN NOTES

- ALL LANDSCAPED AREAS SHALL BE IRRIGATED USING AN AUTOMATIC IRRIGATION SYSTEM THAT WILL BE COMPLIANT WITH THE STATE'S WATER EFFICIENT LANDSCAPE ORDINANCE.
- TREE PLANTING LOCATIONS, INCLUDING WELLS, ISLANDS, PARKWAYS, MEDIANS, ETC. SHALL PROVIDE ADEQUATE UNCOMPACTED SOIL AREA AMENABLE TO ROOT GROWTH. THE DEPTH OF SUITABLE SOIL SHALL BE A MINIMUM OF 24 INCHES AND A MAXIMUM OF 36 INCHES UNLESS OTHERWISE APPROVED.
- ROOT BARRIERS SHALL BE PROVIDED FOR TREES IN LANDSCAPE PLANTERS LESS THAN TEN FEET IN WIDTH OR LOCATED FIVE FEET OR CLOSER TO A PERMANENT STRUCTURE. ROOT BARRIER(S) SHALL NOT INTERFERE WITH MINIMUM PLANTING SITE REQUIREMENTS.
- ALL SHRUB AND GROUND COVER AREAS SHALL RECEIVE A 3" LAYER OF BARK CHIP MULCH TOP DRESSING.
- GROUND COVERS SHALL NOT BE INSTALLED WITHIN A 4" RADIUS OF A TREE TRUNK.